

QTM-DRIVE

LED POWER SUPPLY 60W-200W

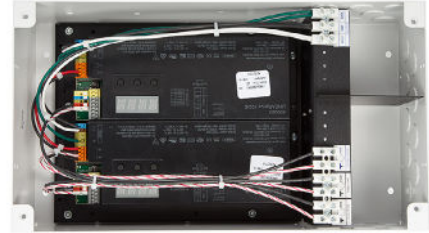

QTM-DRIVE is an LED power supply for DMX or DALI control. It is available in 12 or 24VDC and 60-200 watts of power. The QTM-DRIVE utilizes eldoLED LINEARdrive drivers and is suitable for indoor use. The power supplies and modules are all prewired together along with terminal blocks for power and control wires. The housing can be recessed or surface mounted.



Part Number Builder

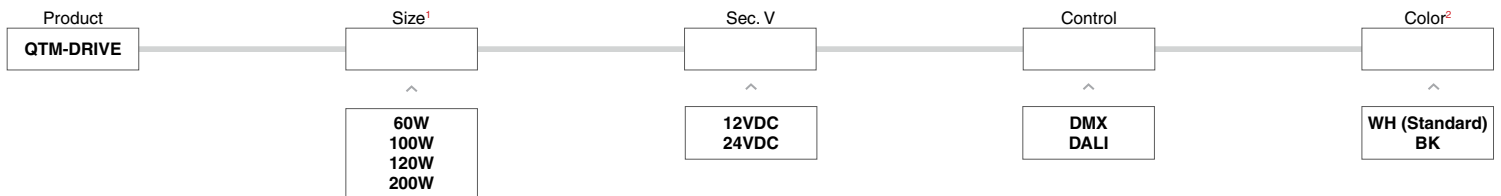

Technical Information

¹ Size

Size	Max Load (Watts)	Secondary Voltage (12/24VDC)	Max Prim Amps @ 120V	Max Prim Amps @ 277V
60W	1x60W	12VDC	0.60A	0.45A
120W	2x60W	12VDC	2.10A	0.90A
100W	1x100W	24VDC	1.05A	0.45A
200W	2x100W	24VDC	2.10A	0.90A

² Color

WH White (Standard)
BK Black Powder Coat Finish

Voltage Drop Chart

VDC	Watts (W)	10 AWG (5.6mm ²)	12 AWG (3.3mm ²)	14 AWG (3.0mm ²)	16 AWG (1.3mm ²)	18 AWG (0.78mm ²)	20 AWG (0.50mm ²)	22 AWG (0.33mm ²)	24 AWG (0.22mm ²)	26 AWG (0.13mm ²)
		12	12	315'	198'	125'	78'	49'	31'	19'
	25	115'	72'	45'	28'	18'	11'	7'	4'	4'
	60	7'	4'	3'						
24	17	897'	564'	355'	223'	140'	88'	55'	35'	22'
	25	567'	356'	224'	141'	88'	56'	35'	22'	14'
	40	309'	194'	122'	77'	48'	30'	30'	12'	7'
	80	130'	82'	51'	32'	20'	13'	8'	5'	3'
	100	84'	53'	33'	21'	13'	8'	5'	3'	

*Distances are based on a 5% Voltage drop max.

• This product must be installed in accordance with the applicable installation code by a person familiar with the construction and operation of the product and the hazards involved



QTM-DRIVE

LED POWER SUPPLY 60W–200W

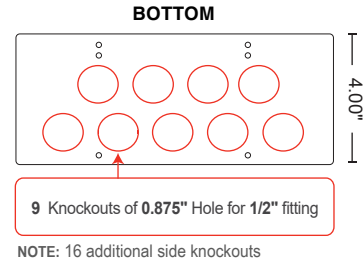
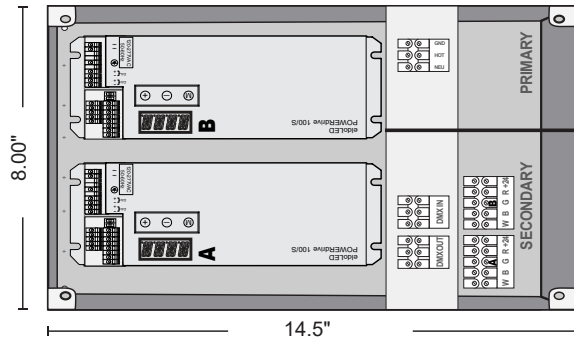

Housing

- 18 gauge welded steel enclosure: 14.5"W x 8.00"H x 4.00"D
- Door: 15.5"W x 9.00"H
- Knockouts: 9
- Built-in support bracket incorporated to secure housing for surface mounting

Performance

- Power Supply
 - : Rated for surface mount or recessed use
 - : Fully rated to operate low voltage load at listed wattage (No derating required)
 - : Voltage regulation to 5% or less of rated output voltage
 - : Universal input range of 120-277 Vrms
- Low Voltage Lighting Systems
 - : CSA Class 3425-15 and Class 3425-95
 - : Short circuit protection (SCP)
 - : Overload protection (OLP)
 - : Live tested by the manufacture to ensure proper operation
 - : Manufacturer offers a minimum of 5 years warranty
- Terminal blocks is made of tin plated copper with a voltage rating of 300V and a current rating of 40A

- DMX or DALI controllable
- Can fit up to 2 drivers
- Surface or recess mount capable
- 4x 12/24V controllable outputs per driver
- Standby power: < 0.5W
- Flicker free operation
- Built-in surge protection: 3kV (L to N), 4kV (L/N to GND)
- Efficiency: 90% at full load, \geq 87% above 50W output
- Power factor: > 0.94
- THD @ full load : < 10%

- DMX dimming down to 0.1%
- 3 years warranty
- Class 2 output
- CSA #239924
 - Low Voltage Lighting Systems
 - : CSA class 3425-15 and class 3425-95
 - : CSA standard C22.2 No. 250.0-08 - Luminaires
 - : ANSI/ UL standard 2108 - Low voltage lighting systems
 - : CSA standard C22.2 No 250.13-14 - Light emitting diode (LED) equipment for lighting applications
 - : ANSI/ UL standard 8750 - Light emitting diode (LED) equipment for use in lighting products



DMX in/LedSync out

- Use these connectors when the driver is used in a DMX network. For DMX in, connect the network cable's DMX+, DMX- and DMX shielding wire (the orange/white, orange and brown wire in a CAT5 cable) to the DMX in+, DMX in- and DMX in shield connector respectively. For LedSync out, connect the network cable's DMX+, DMX- and DMX shielding wire to the LedSync out+, LedSync out- and LedSync shield connector respectively.

DALI

- Use these connectors to connect the driver to a DALI network. Always combine a DA+ and DA- connector for either data input or data output. A separate DALI power supply is required to power the DALI bus.

Wiring Diagram

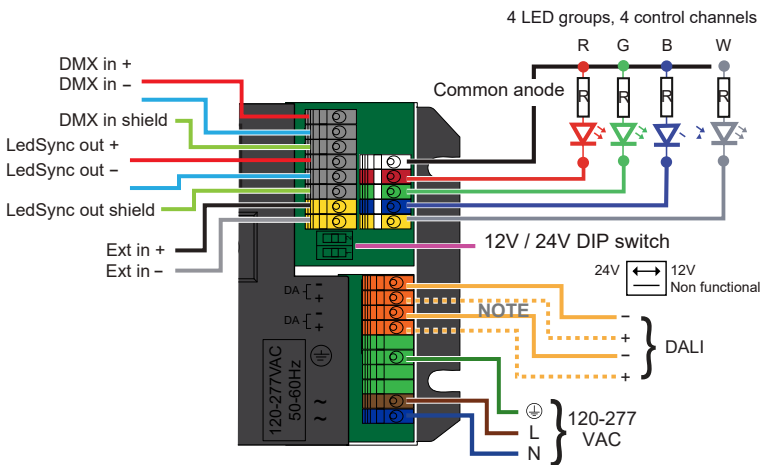

LED wire length: Maximum wire length from LED driver to LED engine at full load:

AWG value	20	18	16
Distance (ft)	46	72	118

NOTE: Longer wire lengths increase EMI susceptibility.

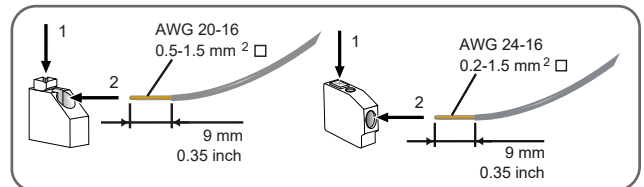

Pay attention when connecting the LED groups:



- polarity reversal results in no light output and often damages the LEDs
- combining + and - of different groups damages the driver

INPUT

- Voltage: 120 - 277 VAC, 50/60Hz
- Current, max per driver:
 - 1.05A at 120V/60Hz
 - 0.5A at 230V/50Hz
 - 0.45A at 277V/60Hz

OUTPUT

- Power per driver: 100W max
- Power per channel: 60W max
- Voltage: 12V/24V output
- Current
 - RGBW @ 12V: 1.25A per output
 - RGBW @ 24V: 1A per output
- Output
 - RGB @ 12V: 1.66A per output
 - RGB @ 24V: 1.33A per output
- Current max: 5A common anode

ENVIRONMENTAL

- Ta operating range : -40°F ~ +122°F
- Tc max : 185°F
- Lifetime : 50K hours at 122°F
- MTBF : 480,000 hours

COMPLIANCE / SAFETY

- Class 2 output.
- Class A sound rating
- FCC: Title 47CFR Part 15 Class B
- The wiring inside electrical enclosures shall comply with the 600V/105 °C or higher.
- CSA certified
 - : UL-2108
 - : UL-8750
 - : CSA C22.2 No 250.0-08
 - : CSA C22.2 No 250.13-14

NOTE: All measurements have been carried out at maximum load in free air without heat sink.



Lifetime data

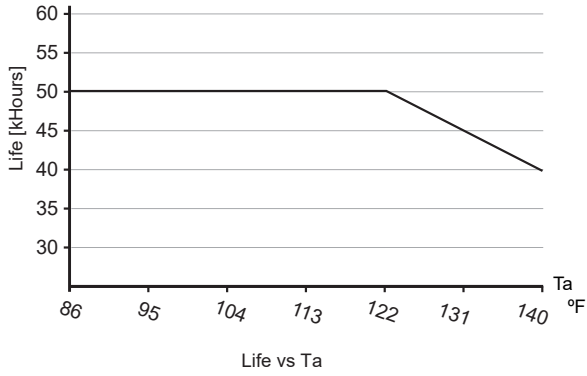

Power factor data

